

Installation Manual

for
602-8V & 602-8VK Wireless Intercom System

Installation

- 1) Before installing fully, test the range of the system. Wire the unit as per wiring diagram, place the equipment in the desired location and test operation.
- 2) Ensure that the gate base station is installed to facilitate line of sight with the property or reception area. To achieve best results, mount the base as high as possible from the ground. Should you need to extend range, you can mount the base on a small pole to elevate it a few meters from the ground.

Note: Wood and glass only reduce signal strength by 10-20%. Masonry will reduce signal strength by 20-50% per wall. Metal can totally block signals.

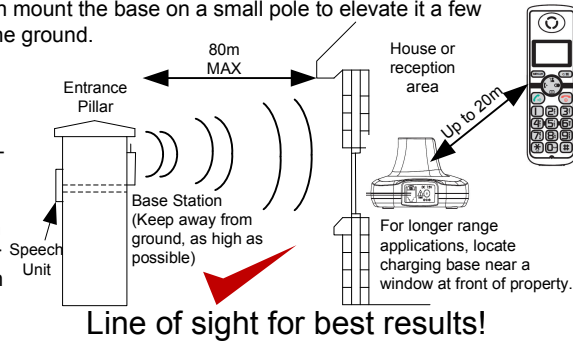

- 3) Power up the master charging base, then install the supplied Mi-MH AAA batteries into the handset as shown.

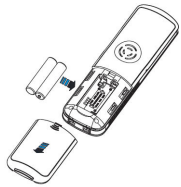

Charge for at least 12 hours before using, otherwise the battery life may be reduced. Please plug in and switch on the master charging base unit BEFORE installing the batteries.



4) Wiring

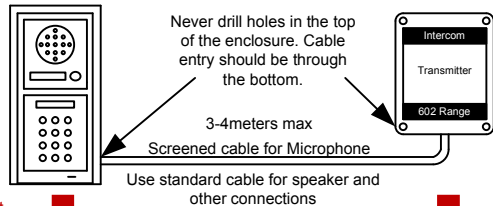

WARNING:
Do NOT connect to C1 or the unit will be damaged and warranty void

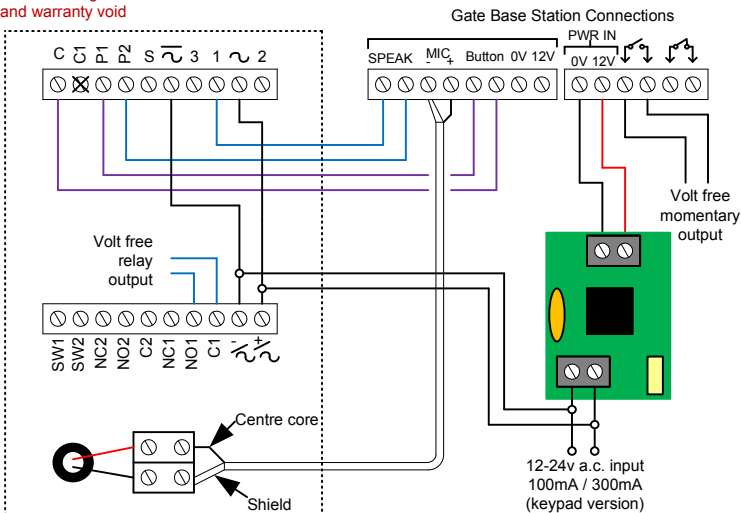

Testing

- 5) Check all connections are correct before switching on the power.
- 6) Press the call button on the speech panel.
- 7) The handset should ring.
- 8) Press the button to answer the call and check two way speech.
- 9) If your system has been connected to a gate system or door release, press and hold the key to activate the release function.

Please note: The gate base station communicates with the main charging base. The charging base then relays the signal internally to the handset. For testing purposes, move the handset to the location where it is likely to be used.

Handset Coding

The supplied handsets will already be coded to work with the door station. Should you have purchased an additional handset individually, please follow this procedure...

- 1) To register a new or additional handset, first put the charging base into learn mode. To do this, press and hold the button on the bottom of the charging base for 7 seconds then release it.
- 2) On the new handset, press key.
- 3) Press or repeatedly to choose REGISTER, then press to select.
- 4) Press or to scroll through the base name list (1-4). and press to select.
- 5) If the base is found, and the handset has successfully registered, you will be prompted to enter a pin code. The default is 0000. The base will now assign a number to the handset, and the handset will return to normal operation mode.

Note: The original base will be base number 1 usually. Register all new handsets to this same base. All additional bases you have are merely to be used simply as chargers. To simplify the coding process, power off all other bases until the handsets are registered with the master base. This will prevent the handsets detecting another base.

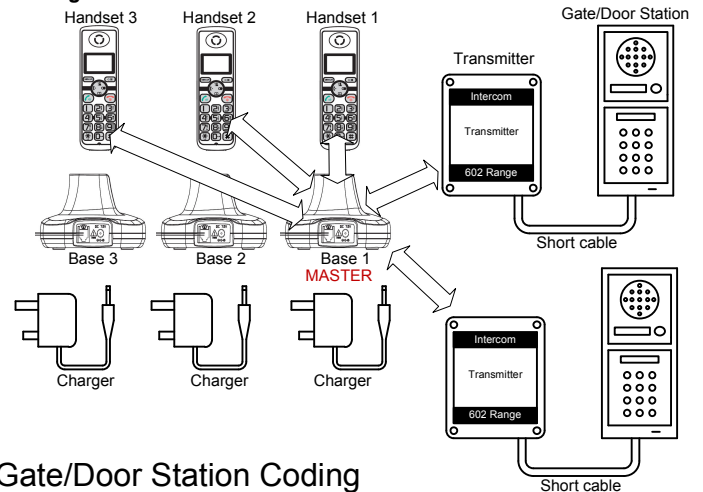

Gate/Door Station Coding

The supplied gate/door station should already be coded with your master base station. If for some reason the system does not work, or you experience interference, it may be necessary to code the gate station.

- 1) On the master charging base station, press and hold button for 7 seconds.
- 2) Ensure the gate/door station is powered OFF.
- 3) On the printed circuit board of the gate/door base station, you will find a micro switch. Press and hold this button.
- 4) Switch on the power to the gate/door station while continuing to hold the code button for several seconds.
- 5) If the outdoor gate/door panel makes a tone, then registration was successful. Release the code button.

Keypad Programming (only for VK model)

